



# EEG HEADBAND

U S E R M A N U A L



# CONTENTS

<b>IN THE BOX</b>	<b>01</b>
<b>IBAND+ FEATURES</b>	<b>02</b>
Sleep Improvement	02
Lucid Dreaming & Sleep Meditation	03
Smart Alarm	05
<b>GETTING STARTED</b>	<b>06</b>
iBand+ Components	06
Connecting your iBand+ for the first time	07
Connecting to a new phone	10
Synchronizing your sleep data	10
Turning OFF Battery Optimization for iBand+ app (for Android only)	12
Pillow Speaker Components	14
Connecting the pillow speakers for the first time	15
<b>EVERYDAY USE</b>	<b>16</b>
<b>KNOW THE APP</b>	<b>18</b>
<b>TROUBLESHOOTING</b>	<b>21</b>
<b>SPECIFICATIONS</b>	<b>22</b>
<b>ATTENTION</b>	<b>23</b>

## **IMPORTANT!**

We strongly advise you to [watch the explainer videos](#) to get a better insight on the iBand+ features.



# IN THE BOX



iBand+ headband



EVA hard case



Wireless pillow speakers



Microfiber cloth



USB charging cable



Free app download

# IBAND+ FEATURES

iBand+ is a smart AI powered EEG brain-sensing headband. With its unique solutions for Sleep Improvement, Lucid Dreaming and Smart Alarm, it's a perfect addition to improve the quality of your life.

iBand+ comes with a pair of stereo pillow speakers that go underneath your pillow to play the application specific audio.

**We all sleep differently. Many factors such as age, the amount of recent sleep or wakefulness, stress, etc. influence the brainwave characteristics that define our sleep stages.**

**It is important to note that with time iBand+ will become smarter and its sleep detection will get better and better as we continue training the artificial intelligence (AI) machine learning algorithm with varied sleep data.**

## SLEEP IMPROVEMENT

A productive day starts with a great night's sleep. Soothing music is one of the oldest techniques used for meditation and relaxation. The pillow speakers play the sounds and music to calm your mind and induce sleep naturally. With its smart machine-learning algorithm, iBand+ tracks your brainwaves and head movement, and intelligently adjusts the music and the volume as you fall asleep. iBand+ detects your sleep stages and turns off the music once you enter from the light to the deep stage of your sleep. It then gently introduces white noise that masks distractions ensuring a sound sleep enabling you to get optimal deep sleep.

So, in fact, you don't need to sleep longer because you will sleep better! And, improved sleep greatly improves the quality of your life.

Before you go to sleep, select your preferred audio from the pre-loaded instrumental, nature, and water tones included in the iBand+ app.

You can also track your daily sleep statistics and long-term sleep trends when you awake.



## LUCID DREAMING & SLEEP MEDITATION

Lucid Dreams are an incredible and the most authentic VR experience, a world unrestrained by the laws of physics!

**BUT WHAT IS A LUCID DREAM?**

A lucid dream is any dream in which you become aware that you are dreaming without waking up. This self-awareness in dreams is the key to lucid dreaming, and iBand+ is your perfect guide to achieve it!

The Sleep Meditation feature with the brainwave entrainment technique is an excellent way to train your brain for lucid dreaming.

Brainwave entrainment is the ability of the brain to naturally synchronize brainwaves with a steady rhythmic external stimulus like light and sound. iBand+ sleep meditation with brainwave entrainment conditions your brain to associate these rhythmic audio-visual stimuli with your dreams.

### **HOW DOES EVERYTHING WORK?**

1. Before you start sleep meditation, you can set the desired audio-visual options from the iBand+ app settings. The audio list is specifically created to include the pulsing sound embedded with the soothing background music. The visual triggers include the selection from rhythmic flickering of light patterns.
2. Lie in your bed comfortably, ready to sleep, and then start iBand+ sleep meditation. The iBand+ will begin to play your selected audio-visual options.
3. Soothing music calms your mind.
4. Now, visualize your recent dream or think about what you want to dream.
5. Try to remember and consciously associate the pulsing sound and flickering light with this dream. These stimuli get implanted into your subconscious mind as the “Dream Sign”.
6. After about a minute or two into sleep meditation, next time when you see or hear the “Dream Sign”, do a reality check by asking yourself “Is this a dream?”, by either holding your breathe or trying to push your finger into your opposite palm. If you can still breathe or your finger goes through your palm, then you are dreaming! Don’t get too excited. Stay calm. You are lucid dreaming!

**YOU WILL PROBABLY FALL ASLEEP DURING SLEEP MEDITATION, AND THAT’S OKAY.**

Once asleep, iBand+ senses your dream phase by monitoring variations in your brainwaves and head movement. It then plays the “Dream Sign” that appear as anomaly in your dream. You do a reality check and...voila, you realize you’re in a lucid dream!

### **TO INCREASE YOUR CHANCES OF LUCID DREAMING:**

Get a **restful sleep** with the iBand+ “sleep improvement” feature. As the quality of your sleep increases so does the duration of your REM sleep in the later part of your sleep cycle. REM is where you get most dreams.

Keep a **dream diary**. Spend 5-10 minutes as soon as you wake up to remember and write down your dream details in the present tense. It’s recommended to read your dream diary before starting sleep meditation. This will further help enhance the clarity of your dreams.

**Remember, everyone is different and will learn the art of lucid dreaming at a different pace. The iBand+ is an expert tutor - and with your proper engagement, the iBand+ will make this process simple and fun!**

## SMART ALARM

iBand+ has the most advanced smart alarm feature that wakes you gradually with simulated sunlight and sounds at the most optimal period of your sleep cycle, so you wake up refreshed every morning.

**What's the optimal period of sleep cycle for waking up and why is it important?**

A normal sleep cycle occurs in 3 broad stages: Light sleep, deep sleep (together called as non-REM or NREM sleep), and rapid eye movement (REM) sleep. Ideally, the body will pass between these stages several times a night. Waking up in the lightest stage of your sleep cycle is the best!

Fixed-time alarm clock goes off at the time you set it to without considering your sleep stage. Waking to a traditional alarm while in deep sleep may lead to the feeling of incomplete sleep or abrupt awakening and grogginess called as sleep inertia. This can affect your ability to perform even the simplest daily tasks.

**YOU CAN SET THE SMART ALARM FROM THE IBAND+ APP IN JUST TWO SIMPLE STEPS:**

- Alarm time which is the time you wish to wake up, and
- Smart wake window which is the time frame of either 15, 20, 30, or 40 minutes before your alarm time.

iBand+ tracks your brainwaves and head movement throughout the night and always knows exactly what part of sleep you're in. It will trigger the smart alarm at the optimal light sleep period during the smart wake window.

Say Goodbye to groggy mornings with iBand+!

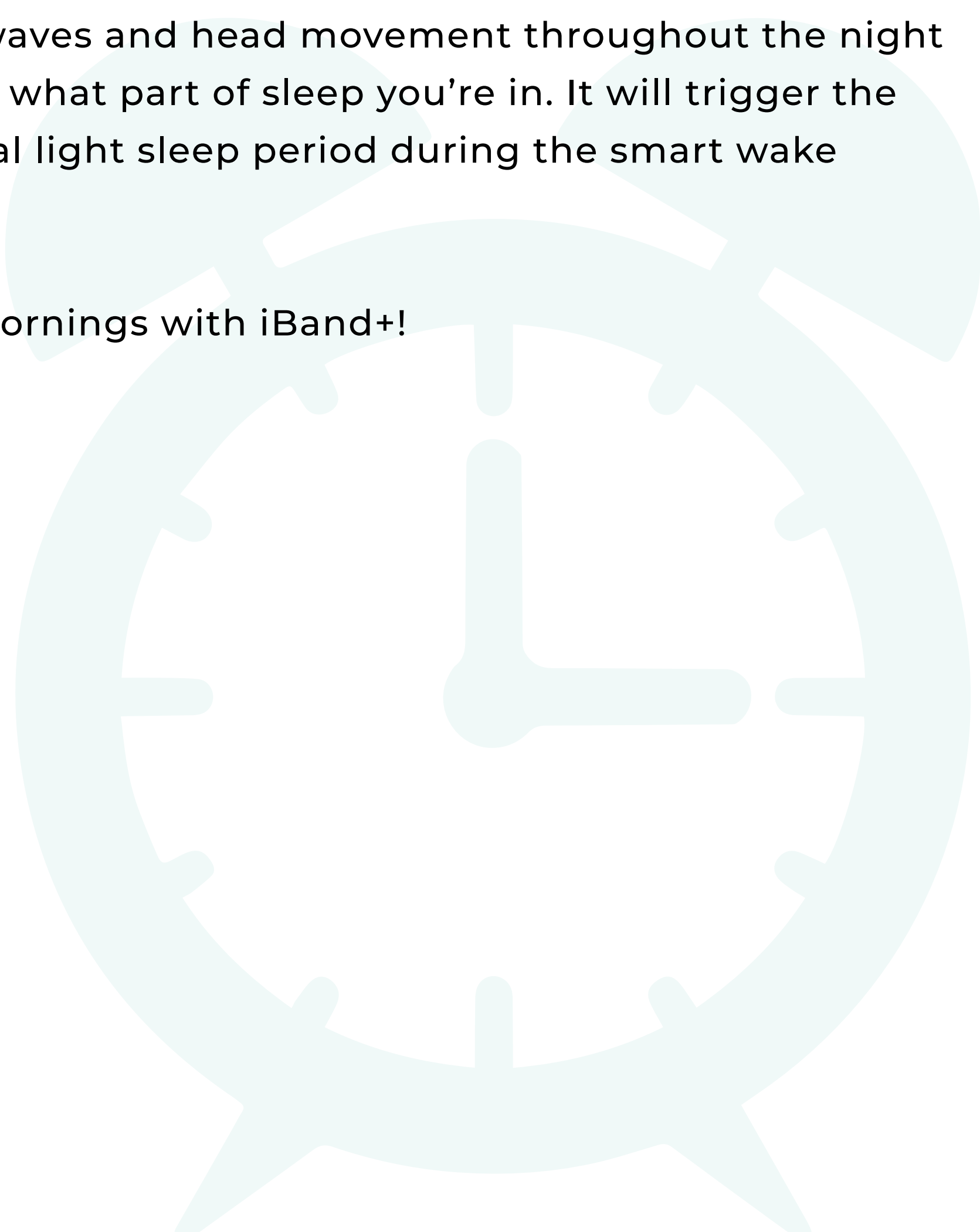

# GETTING STARTED

## IBAND+ COMPONENTS

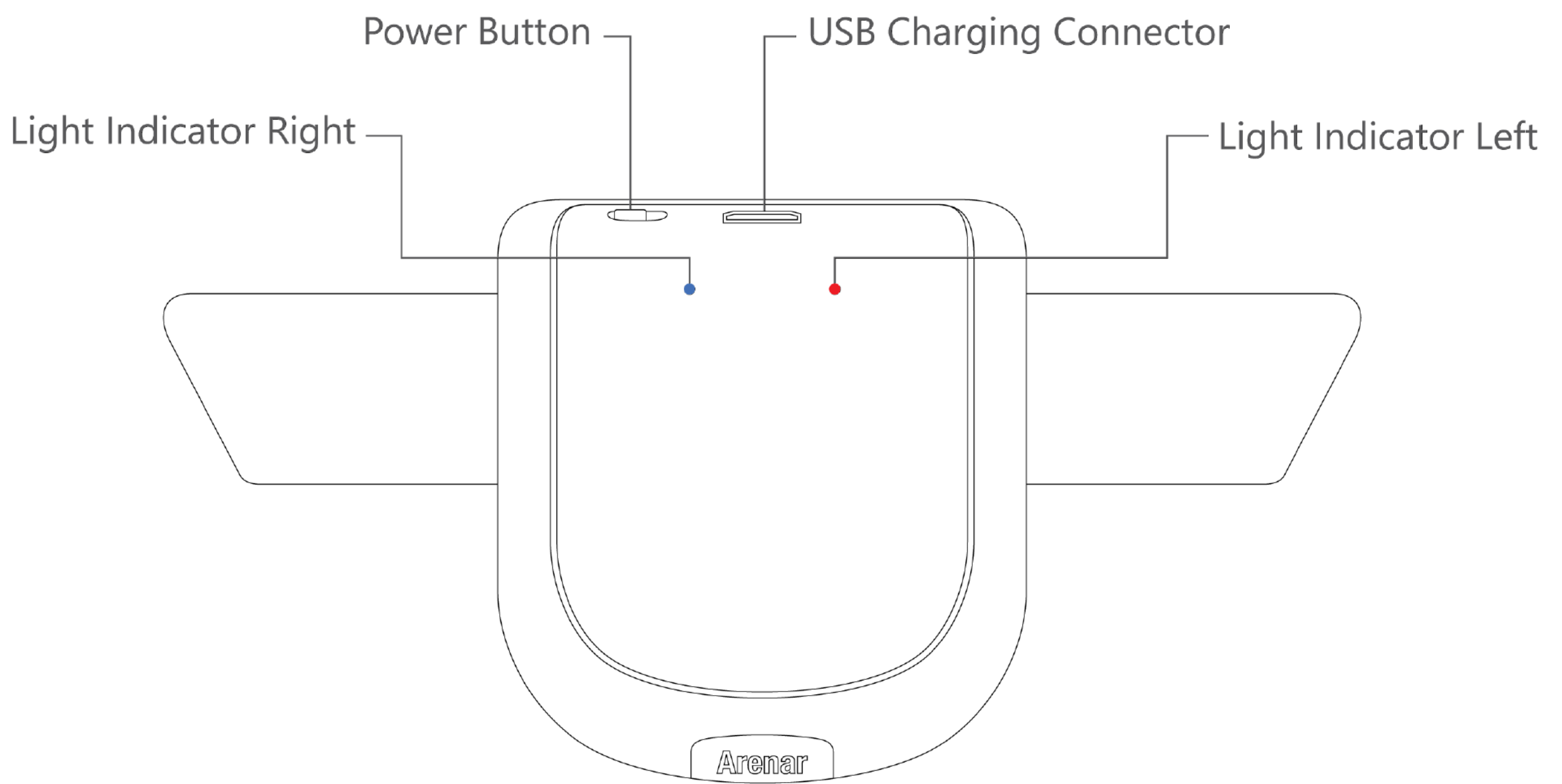

### Gold Plated Dry EEG Electrodes

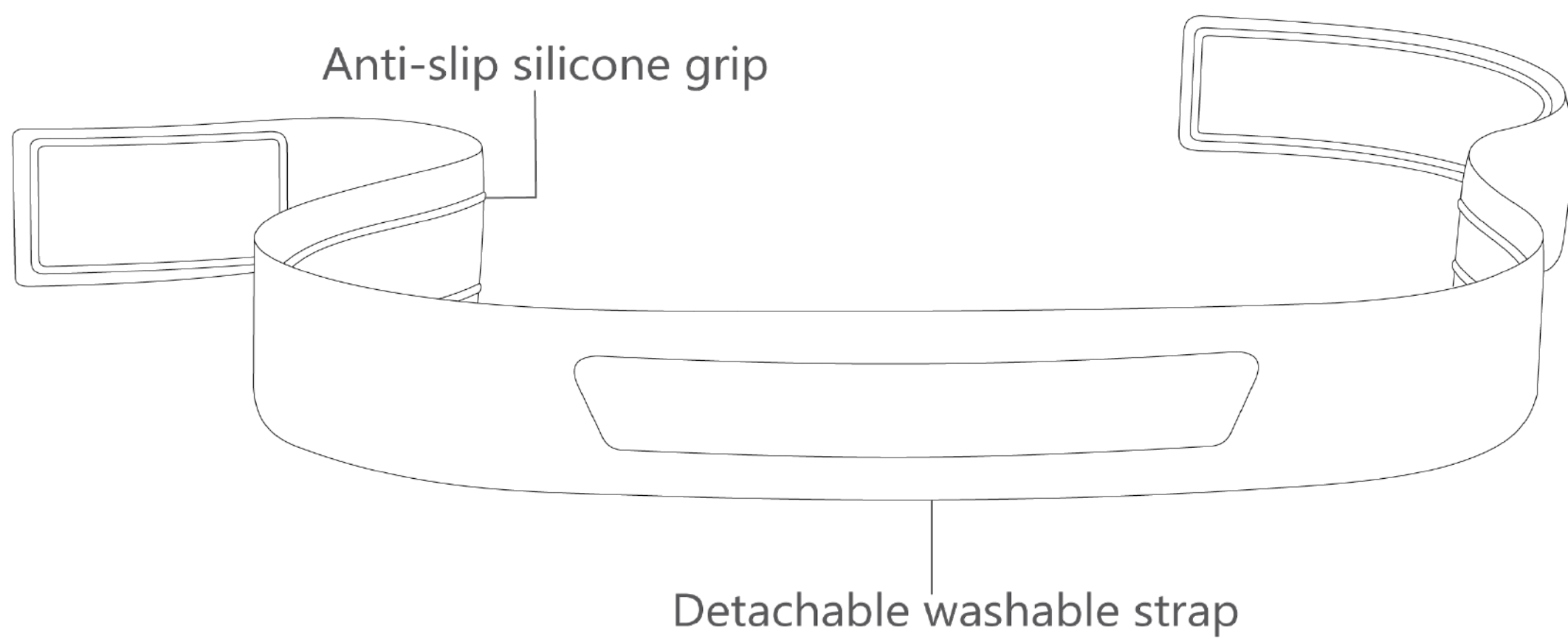
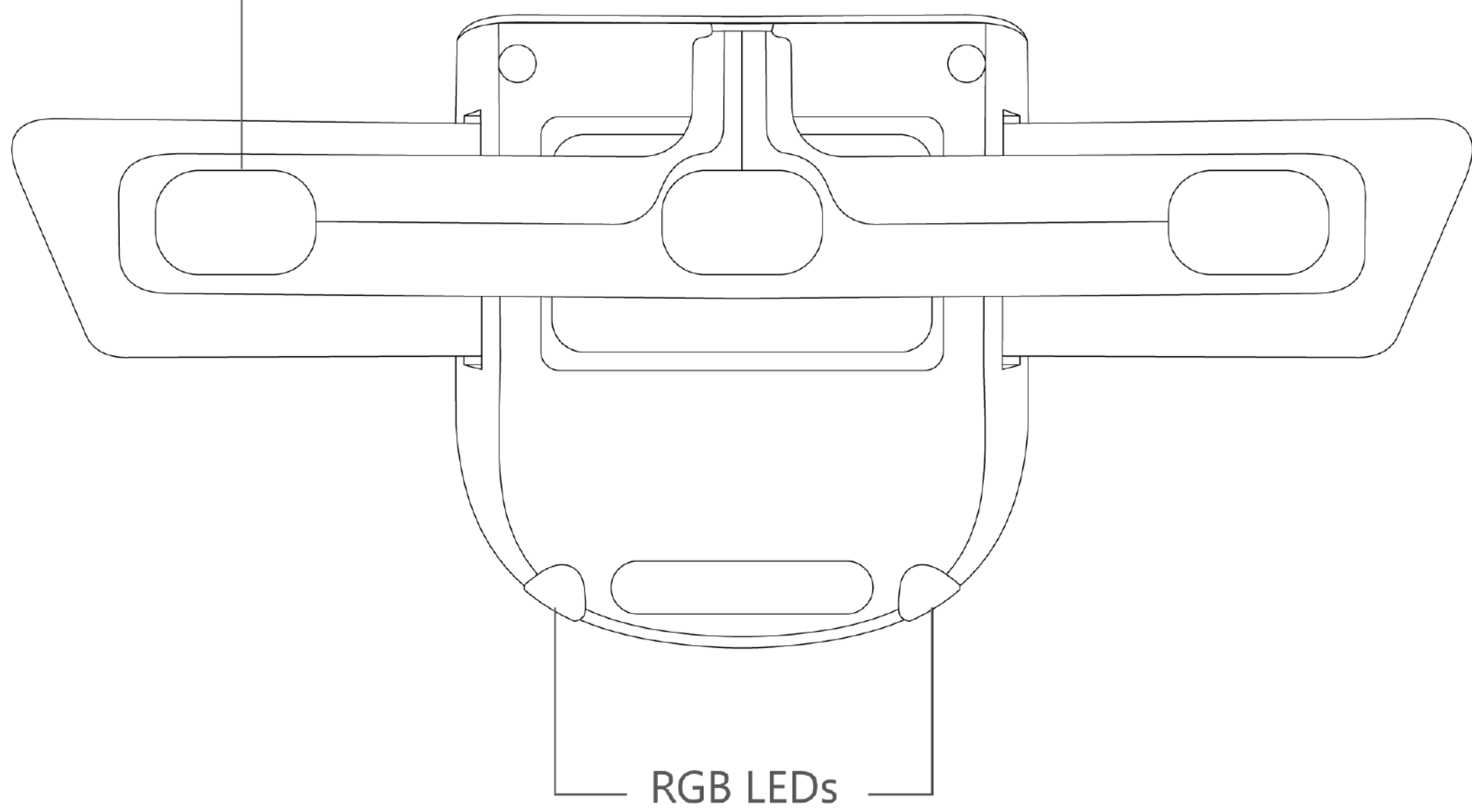



## CONNECTING YOUR IBAND+ FOR THE FIRST TIME

### ONLY FOR THE ANDROID USERS:

Please read this box carefully before you connect your iBand+.

While you sleep, the iBand+ app needs to stay awake to make sure iBand+ plays the application specific triggers whenever you enter from one sleep stage to another. Turn OFF battery optimization on your phone for the iBand+ app. Follow the steps on pages 12 and 13.

The headband and the pillow speakers should be fully charged before using for the first time. Use the provided micro USB cable.

- Turn on the Bluetooth on your phone
- Download the iBand+ app from the App/Play store



### Light Indicators for iBand+

1. When iBand+ is plugged in:

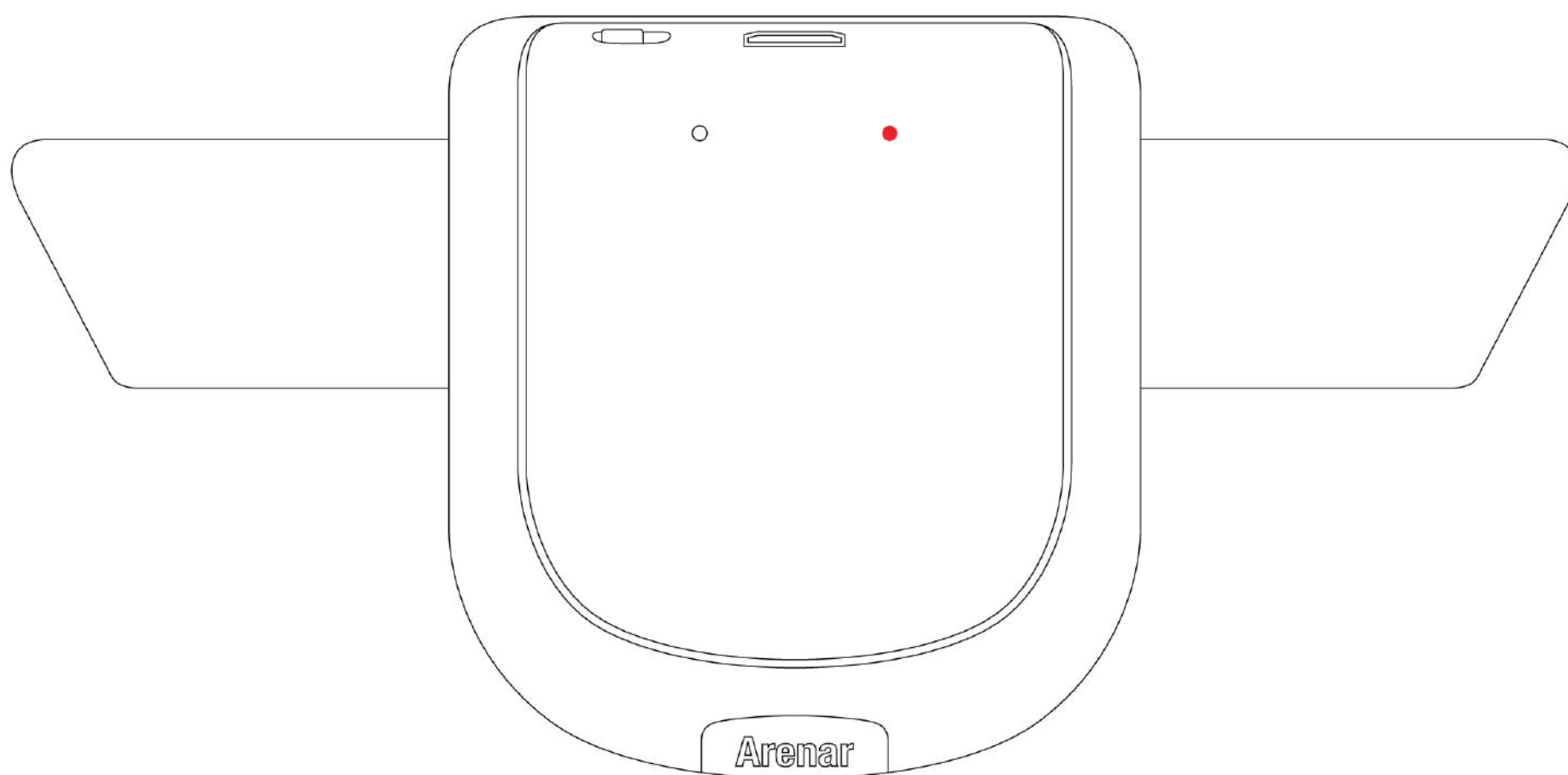

#### SOLID RED LIGHT

Remains ON

iBand+ is charging

Turns OFF eventually

iBand+ fully charged

Turns OFF within 15 secs

iBand+ already fully charged

2. When iBand+ is turned **ON**:

You will see a **SOLID BLUE LIGHT** followed by the RGB LEDs flashing, indicating that the calibration is complete.

iBand+ is now ready to connect to the app.

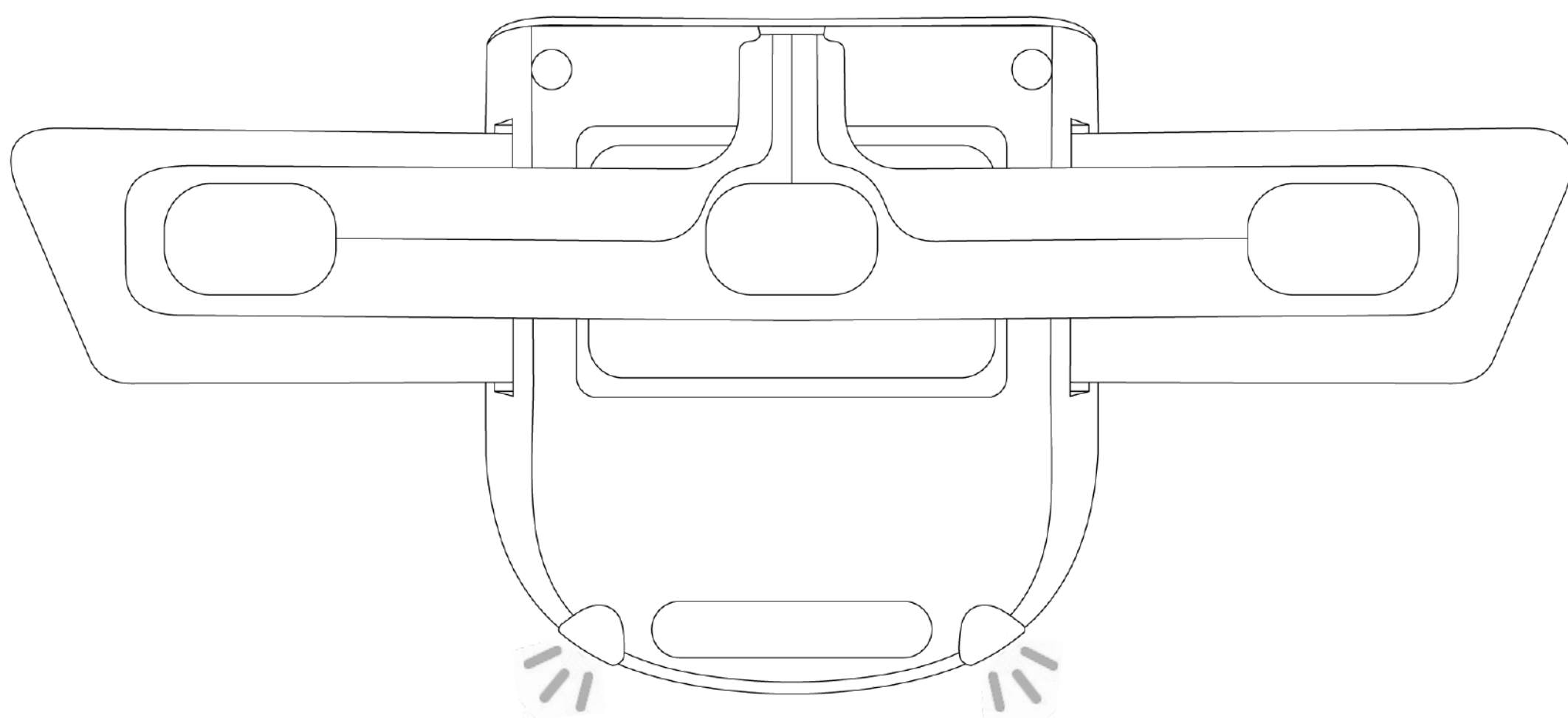
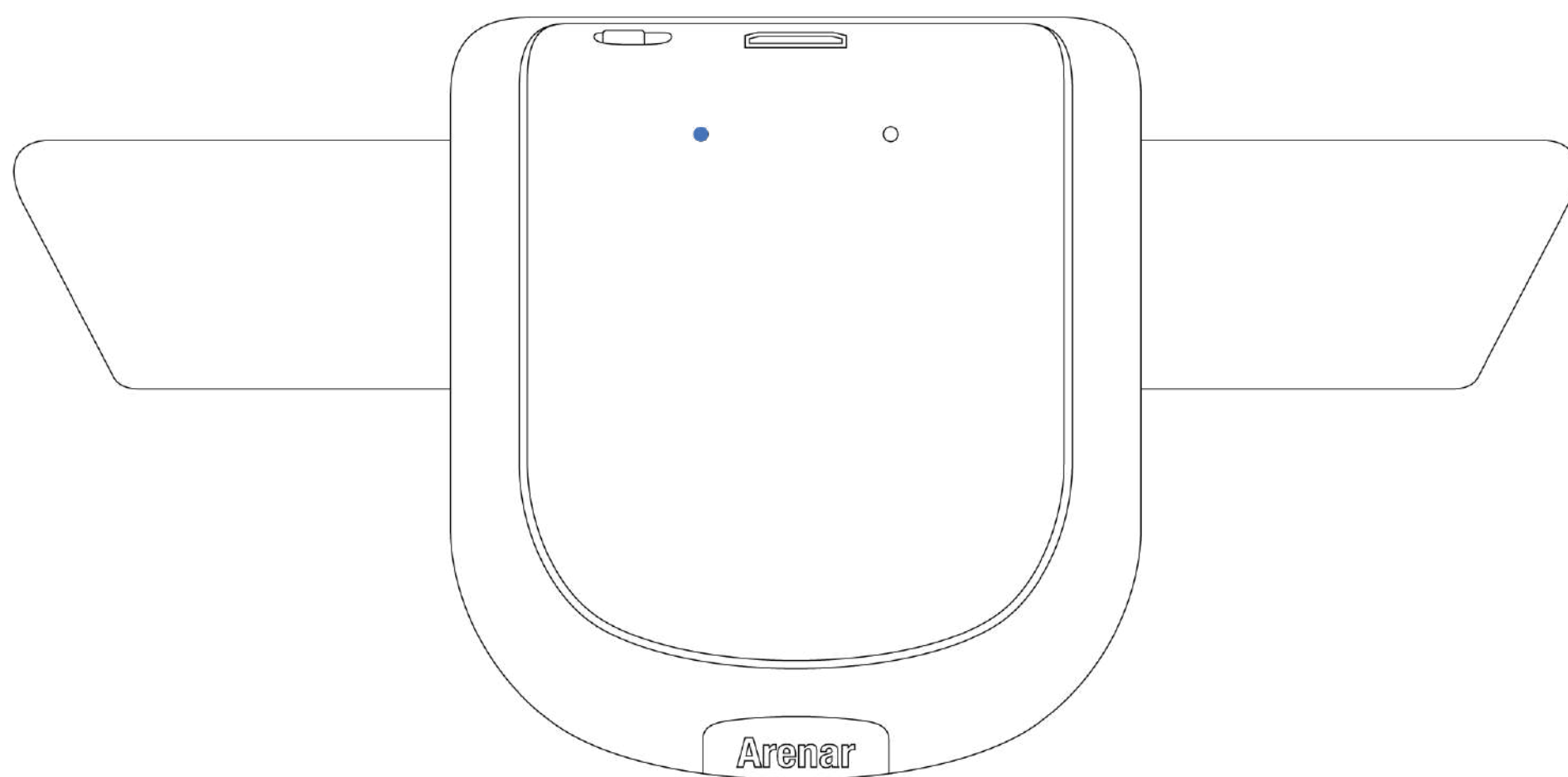

3. Open the iBand+ app  on your phone. Follow the instructions on the app and you are ready to go.
4. Once iBand+ is connected to the app you will be redirected to the app home screen.

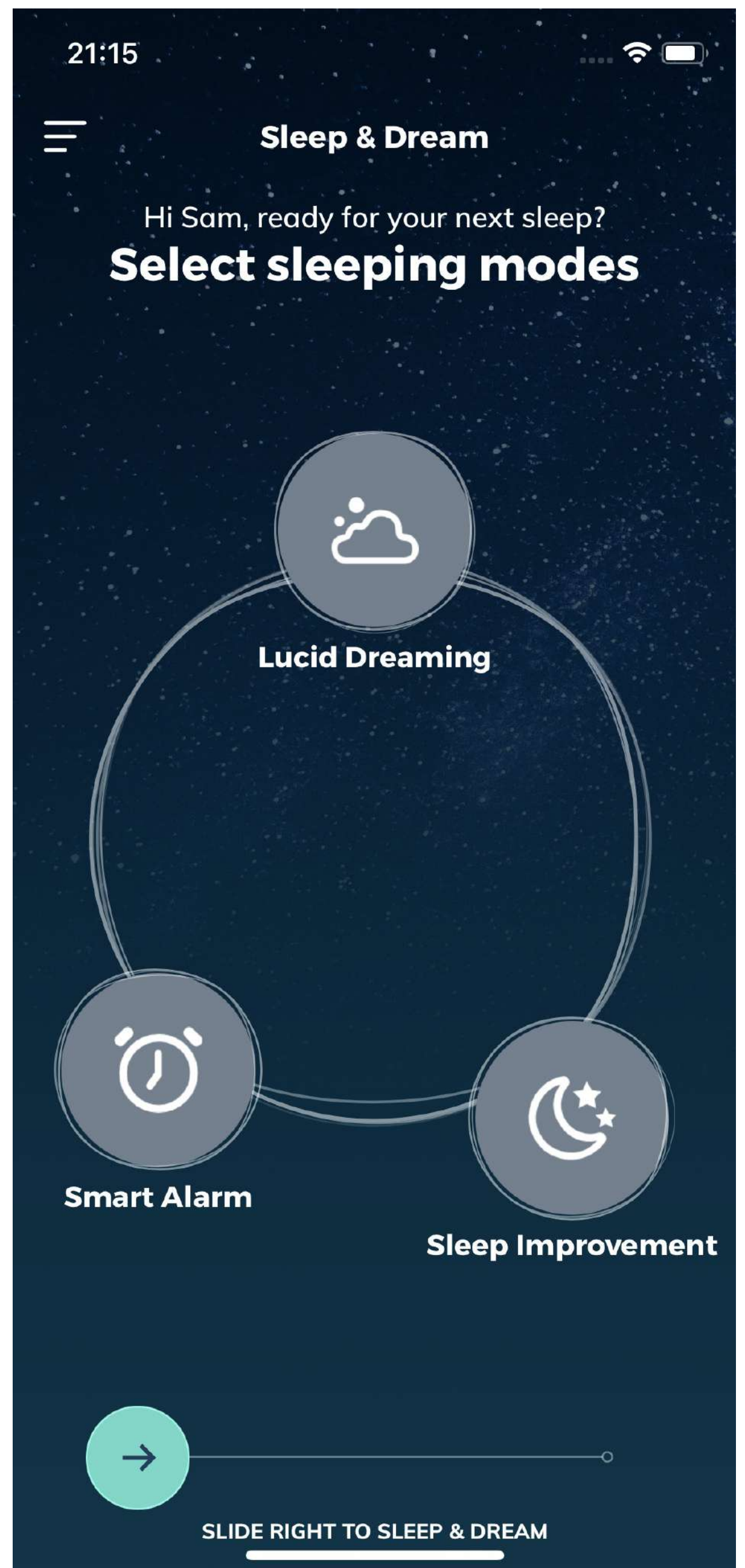
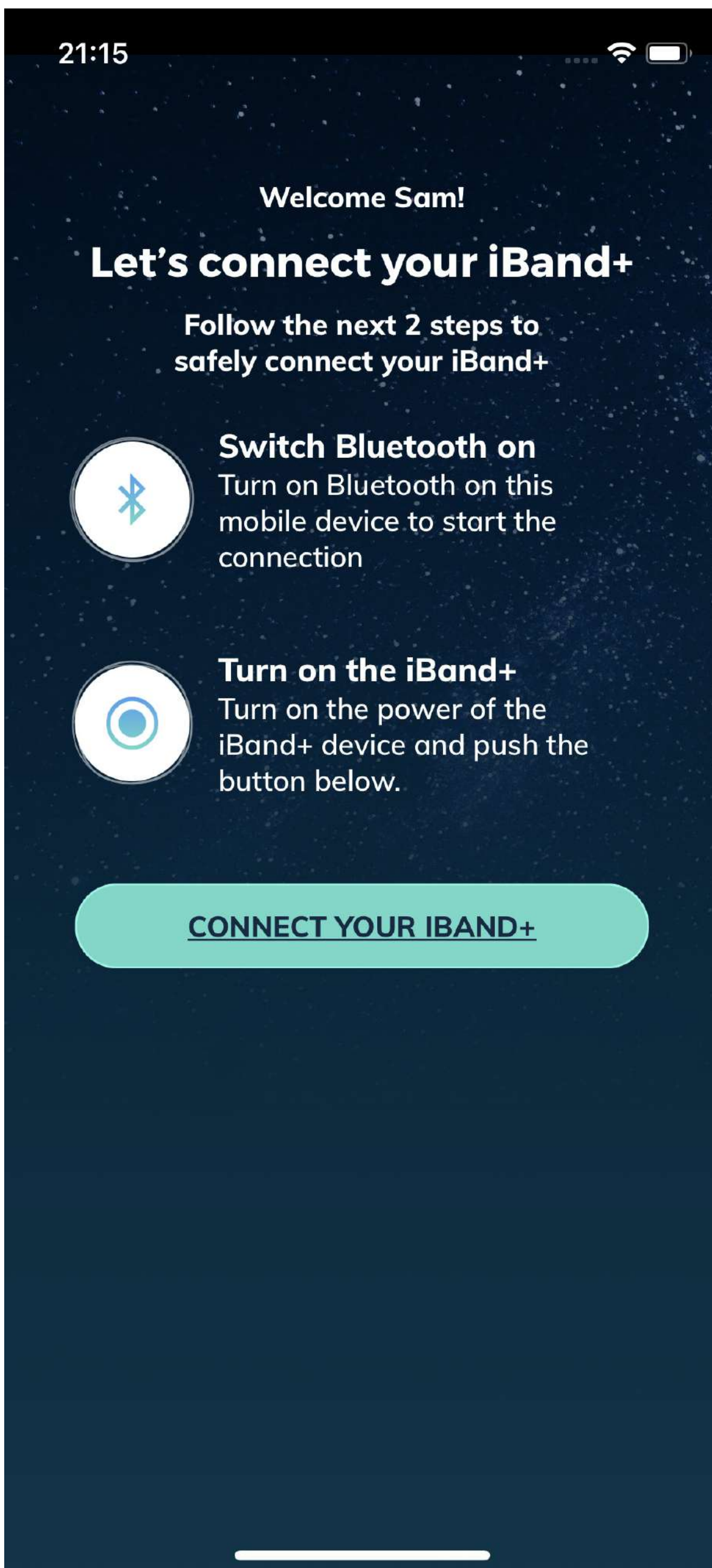



## CONNECTING TO A NEW PHONE

iBand+ will automatically connect to the previously connected phone when turned on. Before connecting your iBand+ to a new phone, remember to first “Forget Device” on your old phone (if applicable).

## SYNCHRONIZING YOUR SLEEP DATA

After you wake up, the first thing to do is **SLIDE LEFT TO WAKE UP**. This will enable the iBand+ to synchronize your sleep data for the previous night with the app. While doing so make sure that iBand+ is **NOT** turned off. You can easily track this data in the Daily Statistics.

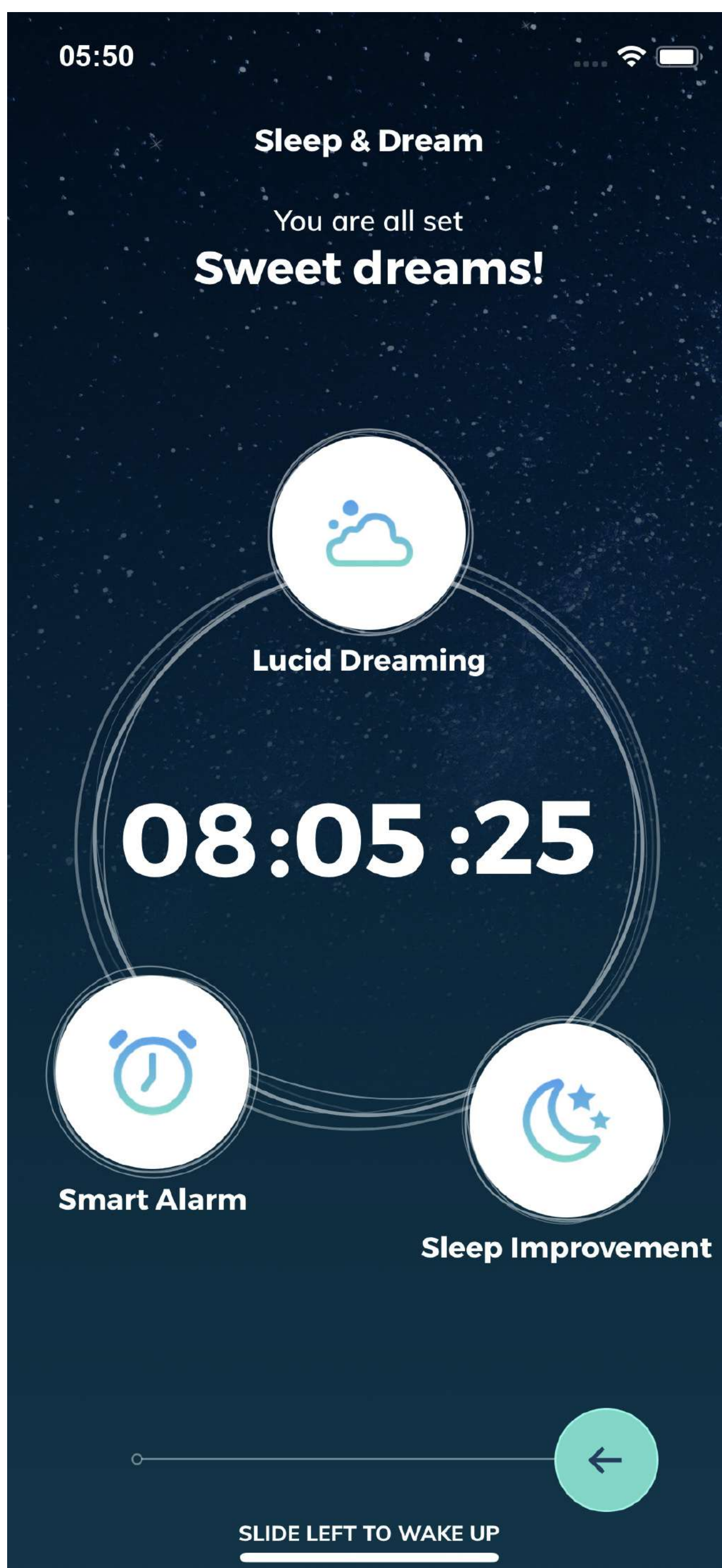

## WHAT HAPPENS IF YOU ACCIDENTALLY TURN OFF IBAND+ BEFORE SYNCHRONIZING?

- You will get a “ble connection failed” error but the data doesn't get lost.
- Whenever iBand+ is turned on the next time and you SLIDE RIGHT TO SLEEP & DREAM you will be asked to synchronize the “unsynced” data from the previous sleep.

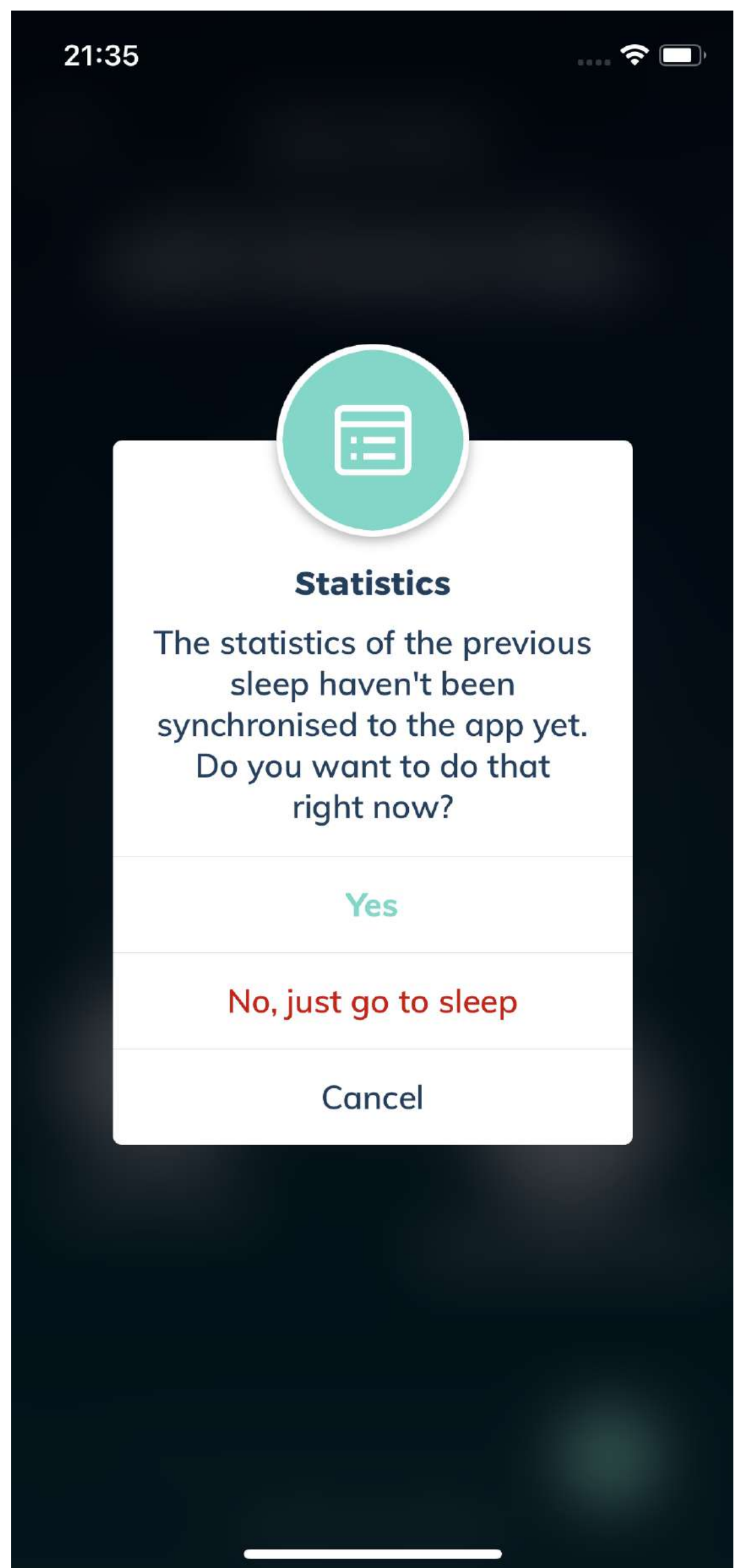
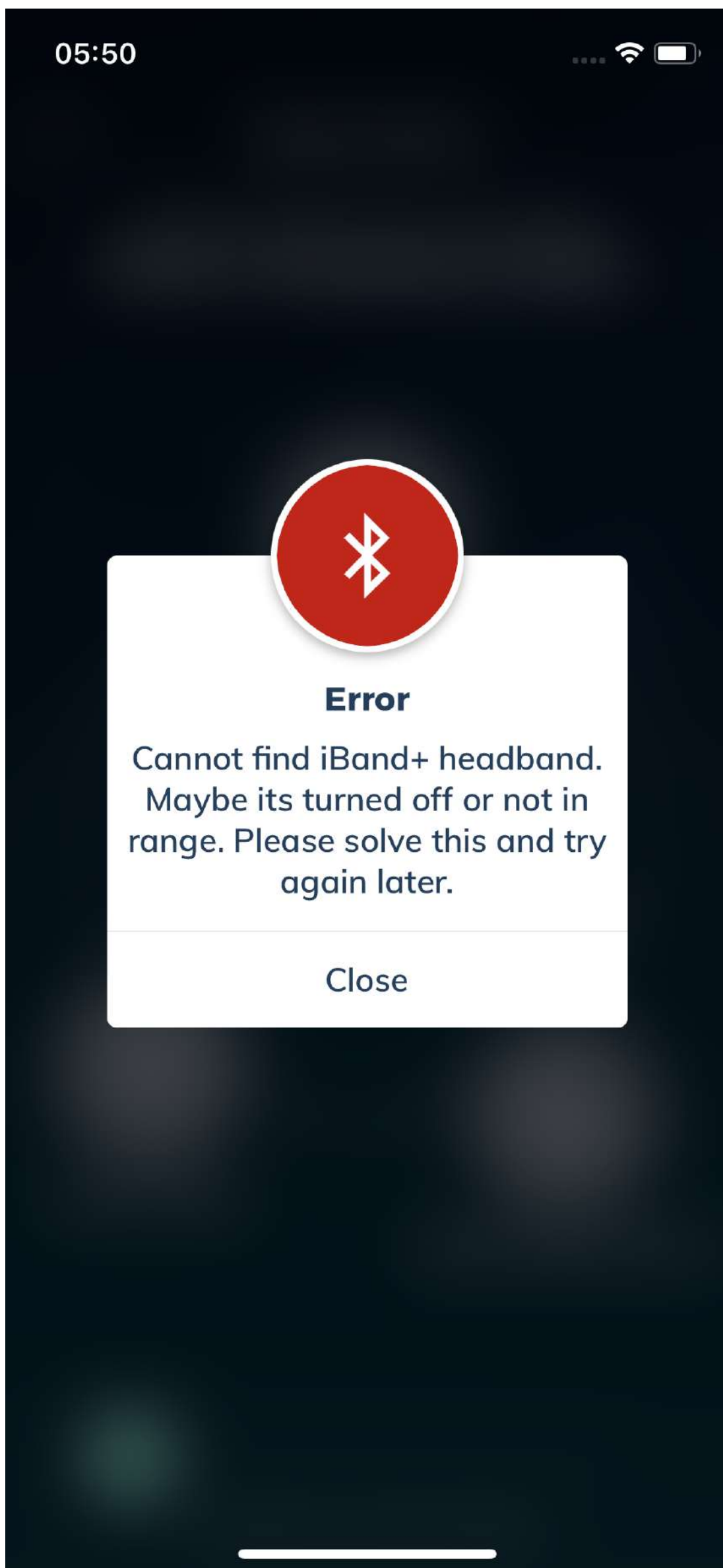

PLEASE NOTE THAT THE UNSYNCD DATA IS AVAILABLE ONLY FOR THE PREVIOUS SLEEP AND NOT THE SLEEPS BEFORE THAT. WE STRONGLY ADVISE YOU TO SYNCHRONIZE YOUR SLEEP DATA AS SOON AS YOU WAKE UP.

**\*\*FOR ANDROID ONLY\*\***

## TURNING OFF BATTERY OPTIMIZATION FOR IBAND+ APP

### FOLLOW THE STEPS BELOW:

1. Go to your phone **Settings -> Battery -> Battery Optimization**
2. Select the iBand+ app from the All Apps list and select **“Don’t optimize”**.

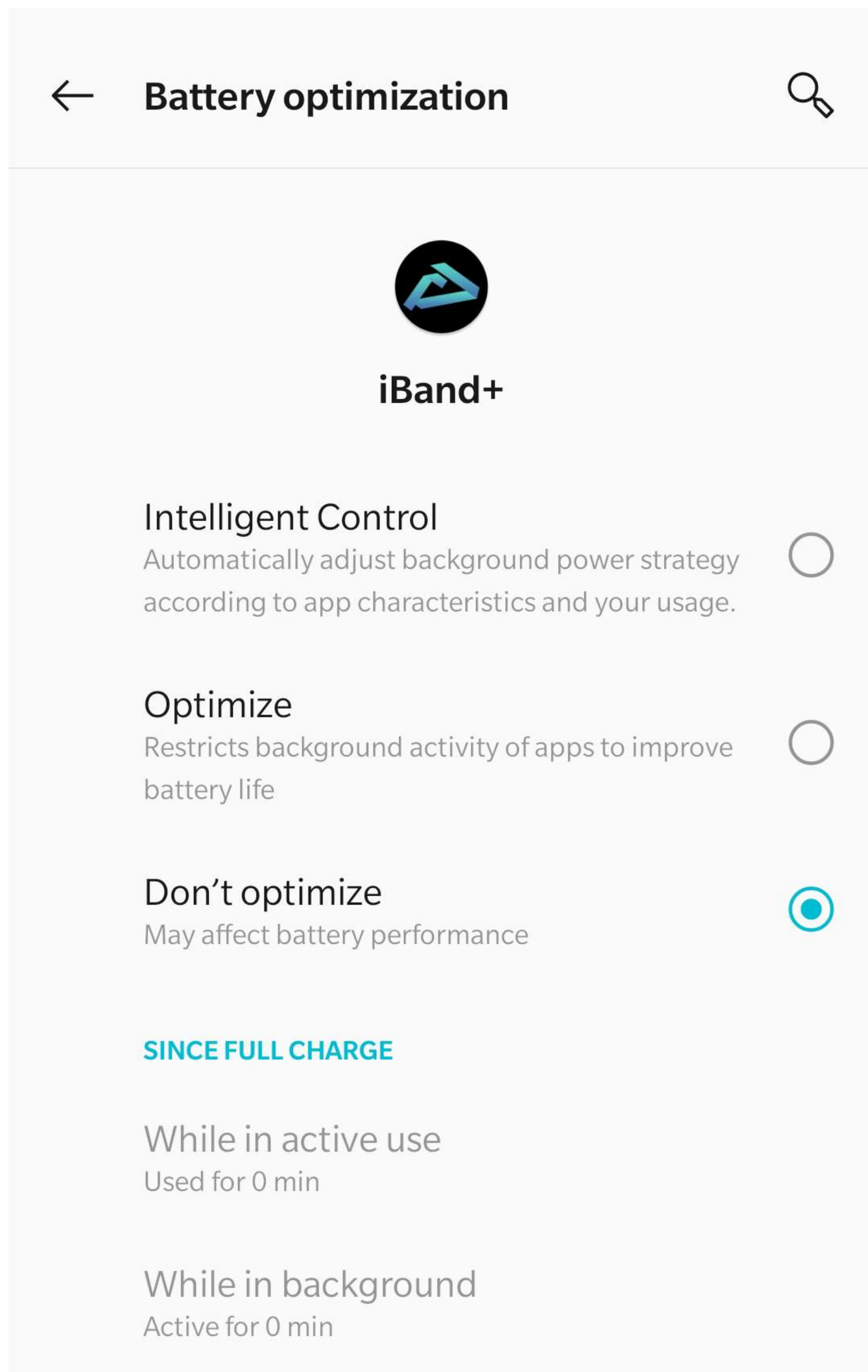



3. Tap back to the **Battery Optimization -> Advanced Optimization**

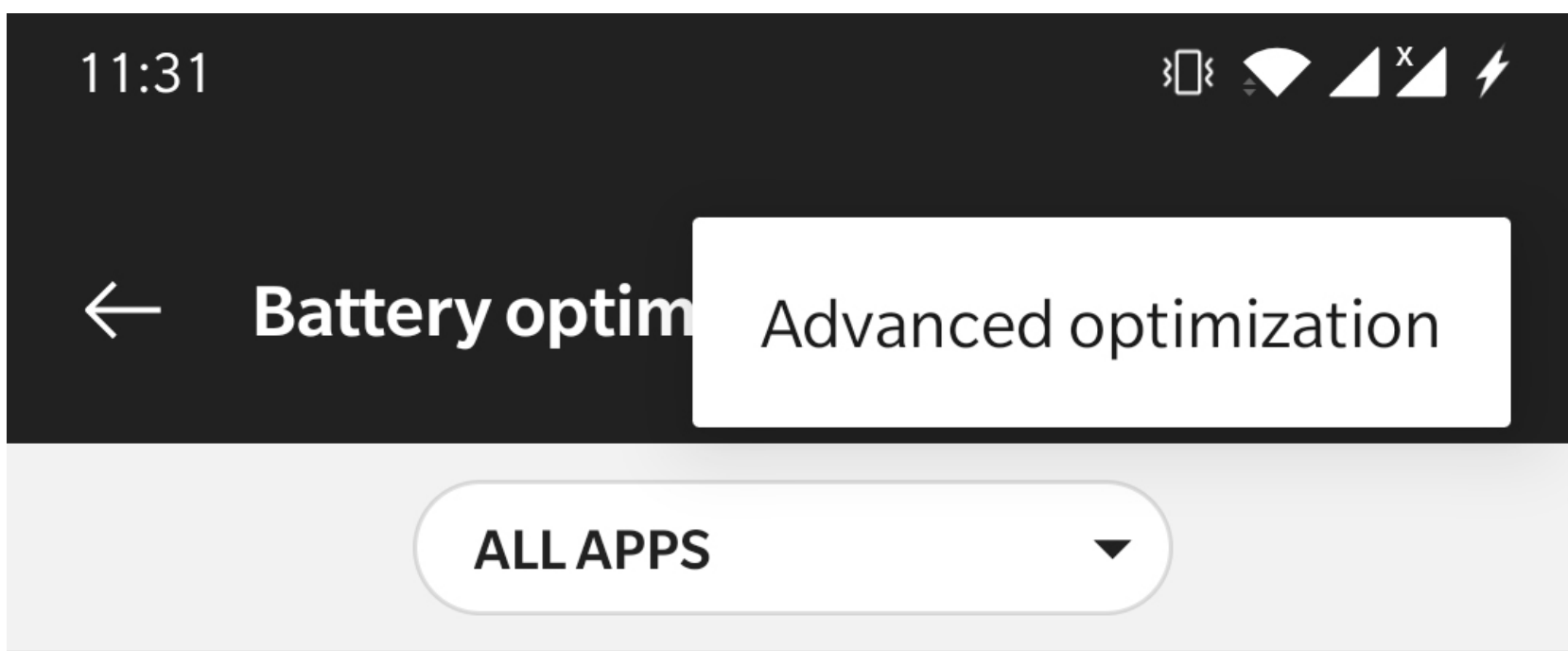

4. Turn **Off** the options in the Advanced Optimization.

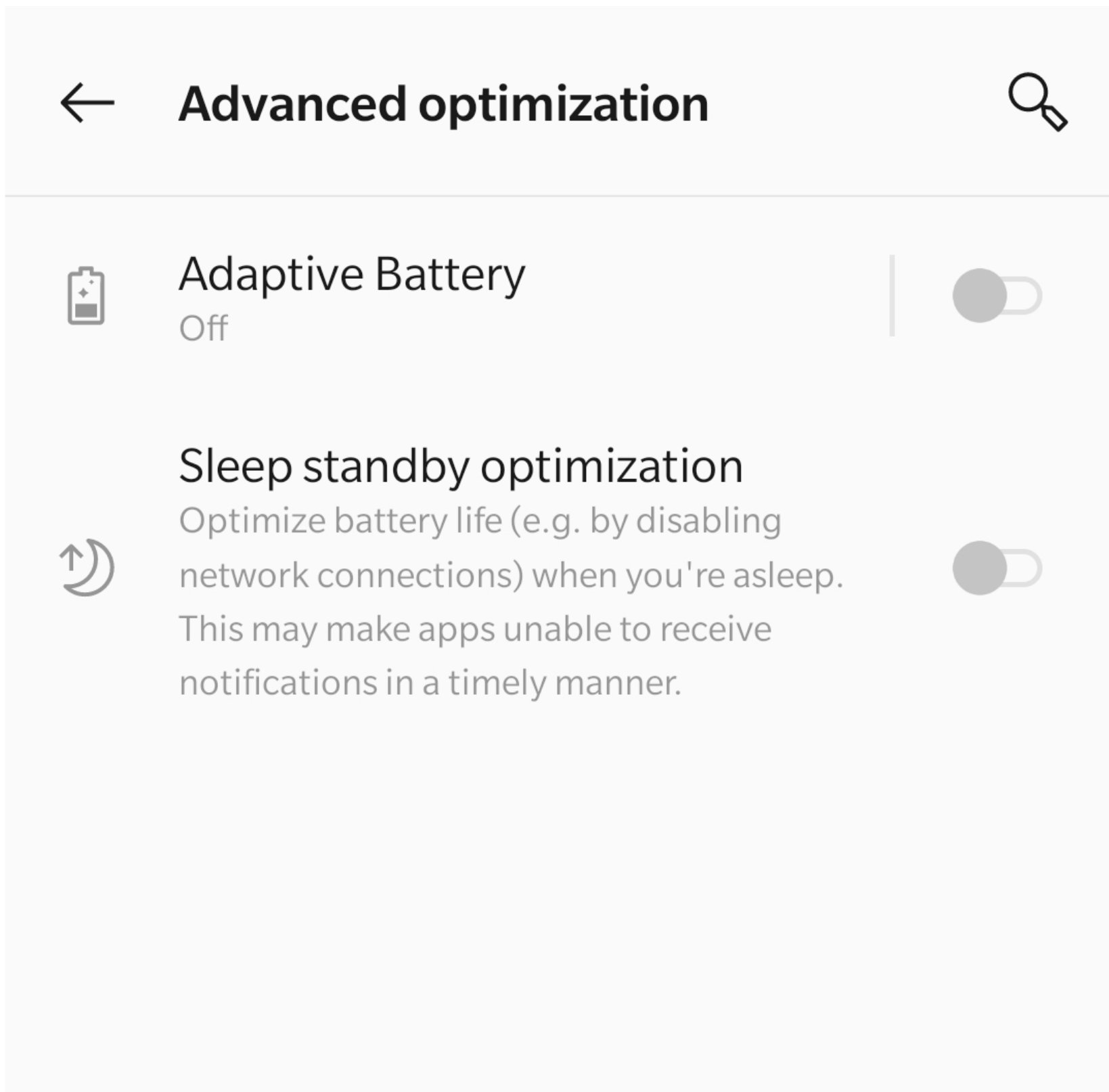

## PILLOW SPEAKER COMPONENTS

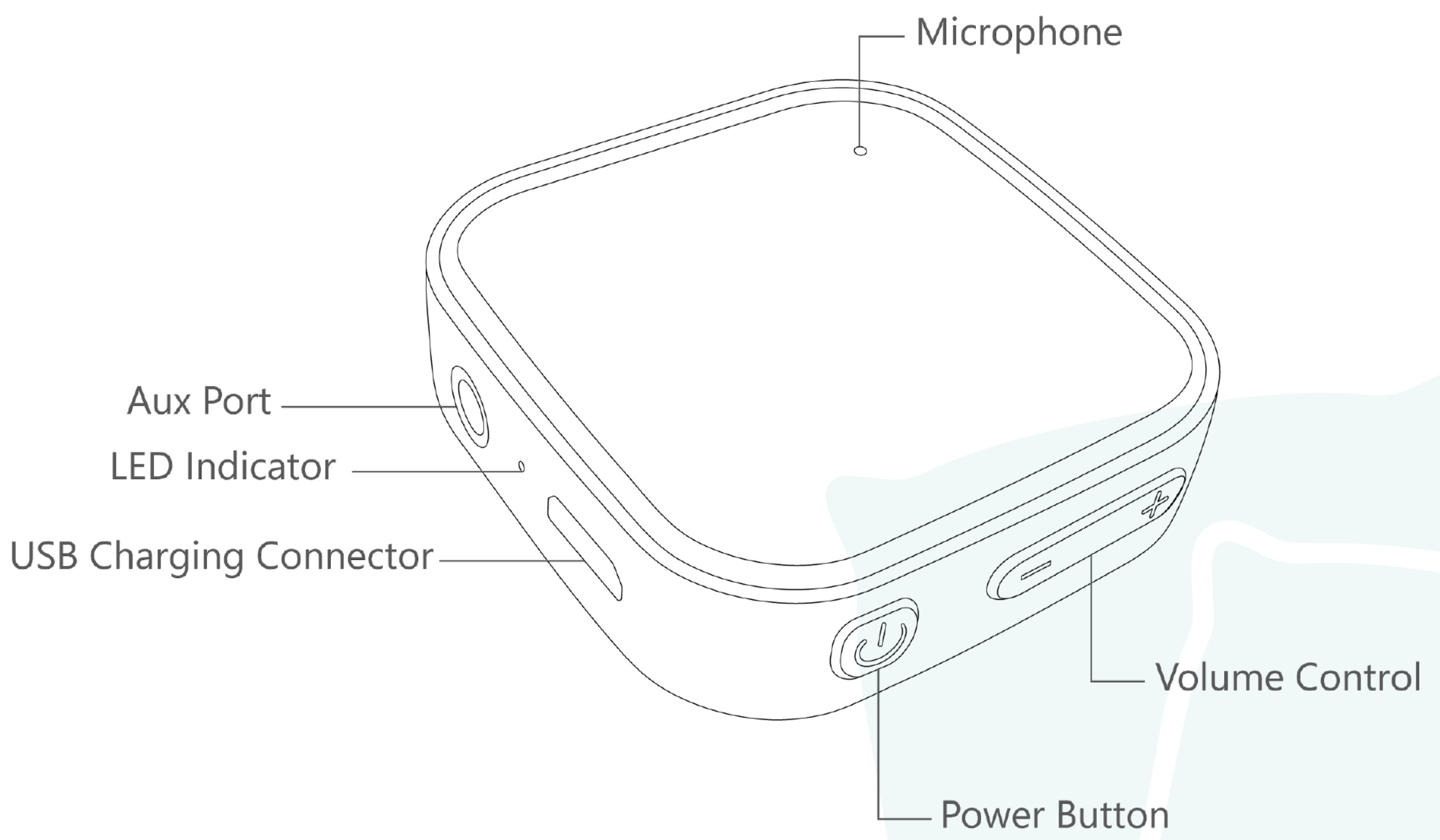
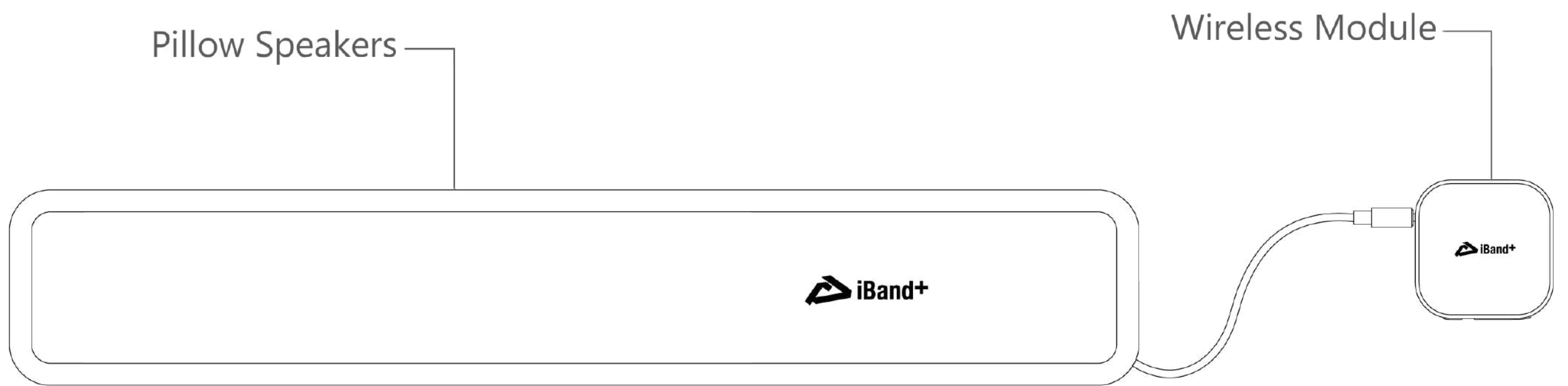

## CONNECTING THE PILLOW SPEAKERS FOR THE FIRST TIME

The headband and the pillow speakers should be fully charged before using for the first time. Use the provided micro USB cable.

Before you start, connect the wireless module to the iBand+ pillow speakers using the AUX port.

### LED INDICATORS:

If the LED **FLASHES**:

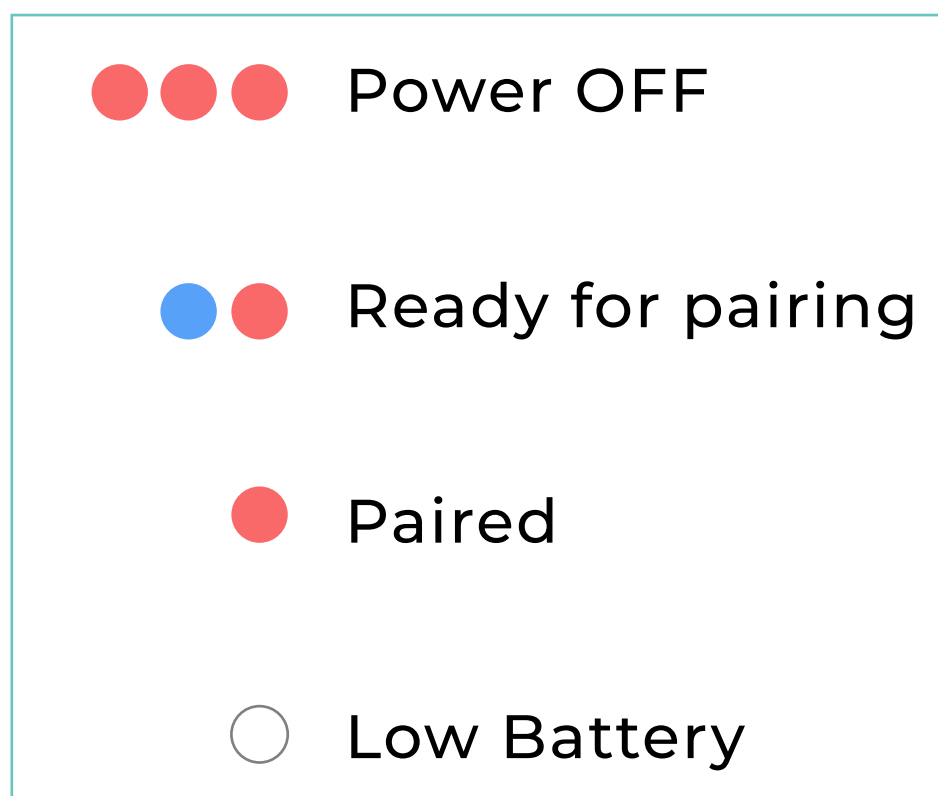

If LED is a **SOLID LIGHT**:

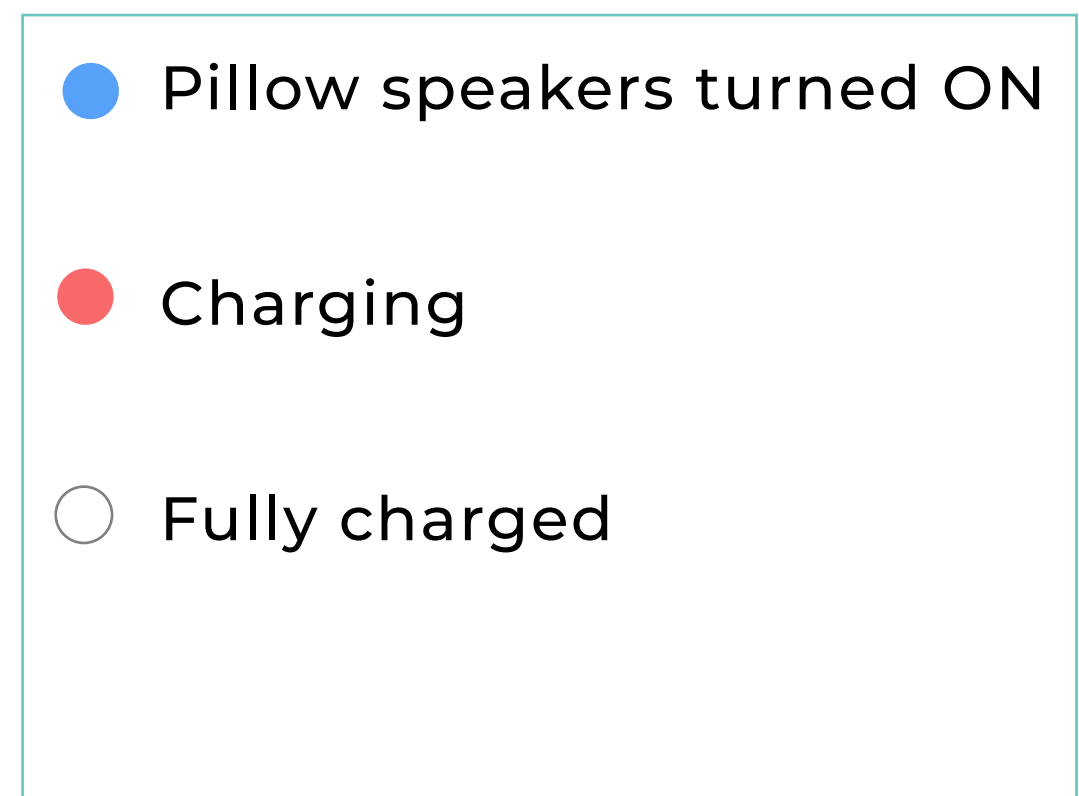

### PILLOW SPEAKER WIRELESS MODULE

1. Hold the power button for 3 seconds to enter the pairing mode. The LED indicator will flash blue and red.
2. Turn on Bluetooth on your phone. Select “iBand+ Pillow Speakers” in your Bluetooth settings. The LED will stop flashing blue and red.

#### **AUTO-CONNECT:**

The iBand+ pillow speakers will automatically connect to the previously connected phone when turned on the next time.

Please turn on the Bluetooth function of your phone **before** turning on the pillow speakers.

#### **AUTO POWER OFF:**

The pillow speakers will power off automatically within 5 minutes if not paired with any device.



## EVERYDAY USE

WE ADVISE YOU TO WATCH THE [“EXPLAINER VIDEOS”](#) FOR THE BEST USER EXPERIENCE.

1. Turn ON your iBand+. It will automatically connect to the paired mobile phone.
2. Ensure that your iBand+ is fitted securely. Adjust the headband such that the sensors are making contact with your skin, without being too tight.
3. Turn ON the pillow speakers. They will automatically connect to the paired mobile phone. Place the pillow speakers under the pillow. Adjust the volume that suits you the best.
4. Open the iBand+ app. Slide right to sleep or start with the Sleep Meditation (auto mode) and that's it.
5. Once awake don't forget to synchronize your sleep data before turning OFF iBand+.

LIKE ANY CHANGE IN HABITS, SLEEPING WITH IBAND+ MAY TAKE SOME TIME TO GET USED TO. WE RECOMMEND GIVING YOURSELF AT LEAST 10 DAYS TO GET USED TO YOUR IBAND+.

## PROPER CARE OF IBAND+

### WASHING INSTRUCTIONS FOR THE HEADBAND STRAP



Hand-washable in luke warm water.

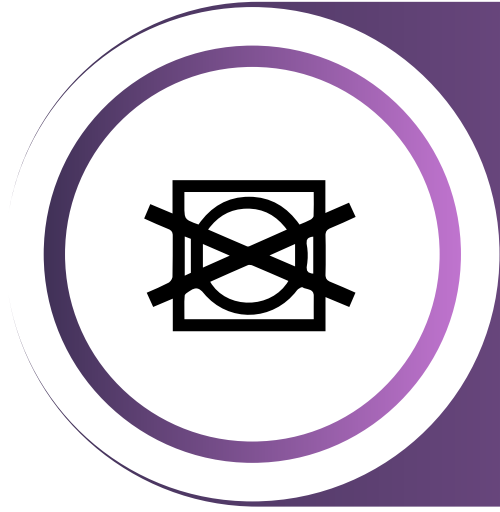

Do not tumble dry.

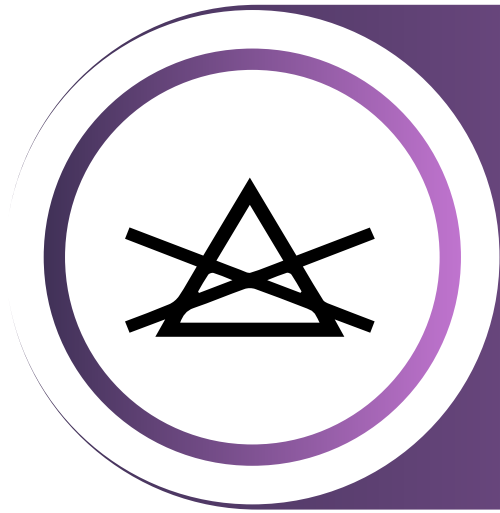

Do not bleach.

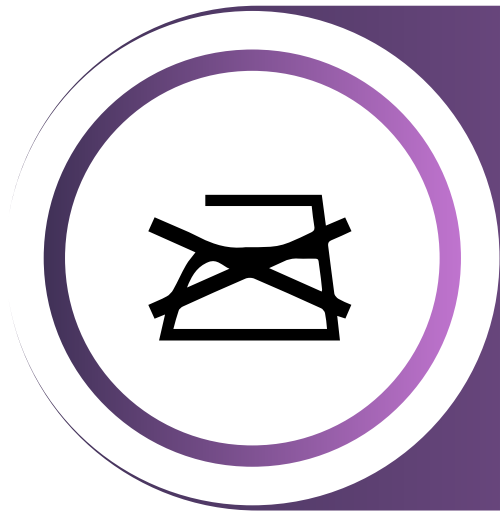

Do not iron.

DO NOT EXPOSE THE IBAND+ HEADBAND TO EXTREMELY HIGH OR LOW TEMPERATURES AND HUMIDITY.

DO NOT OPEN, DISASSEMBLE, OR ATTEMPT REPAIR.



# KNOW THE APP

1. Once on the home page, simply tap the icons to activate/deactivate the desired applications.

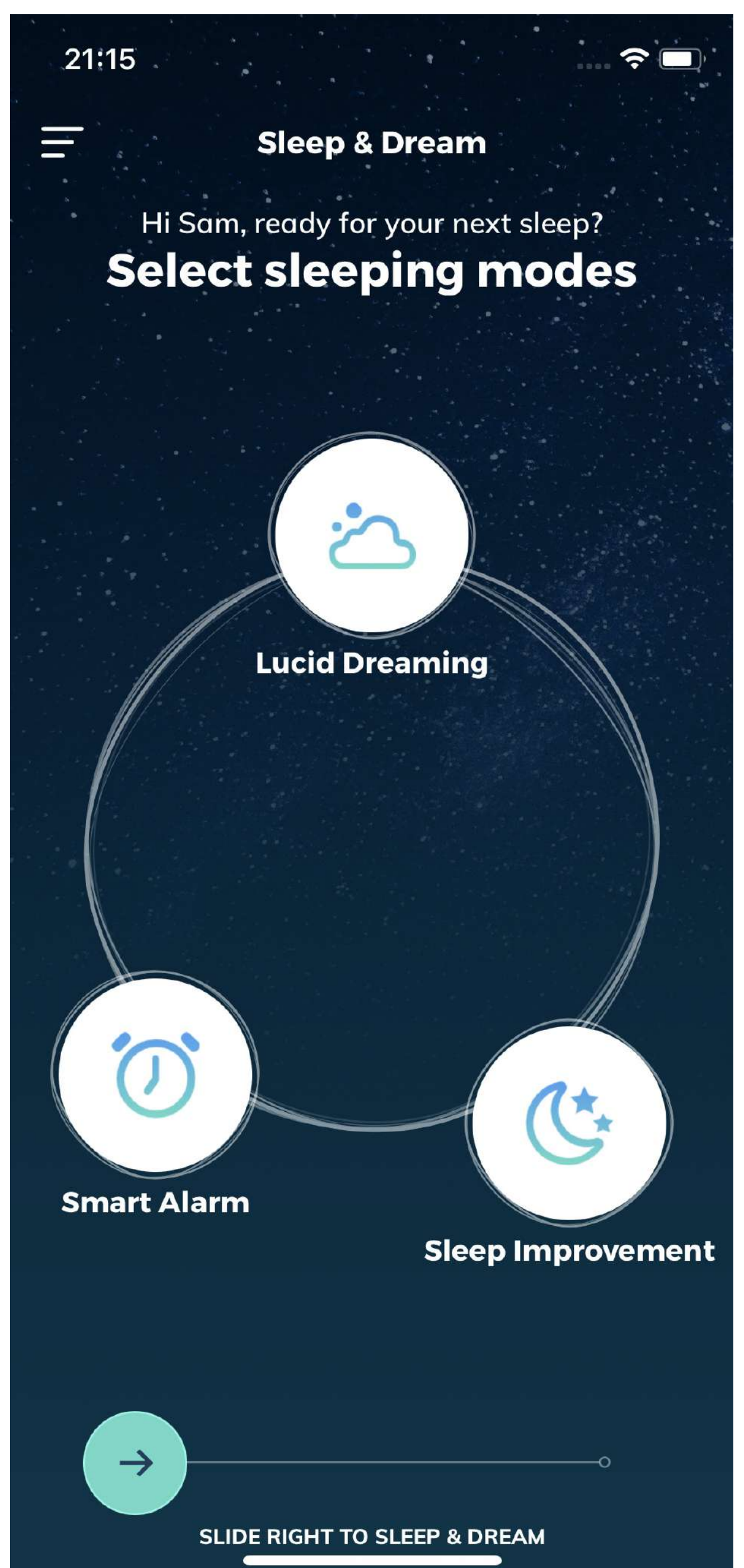
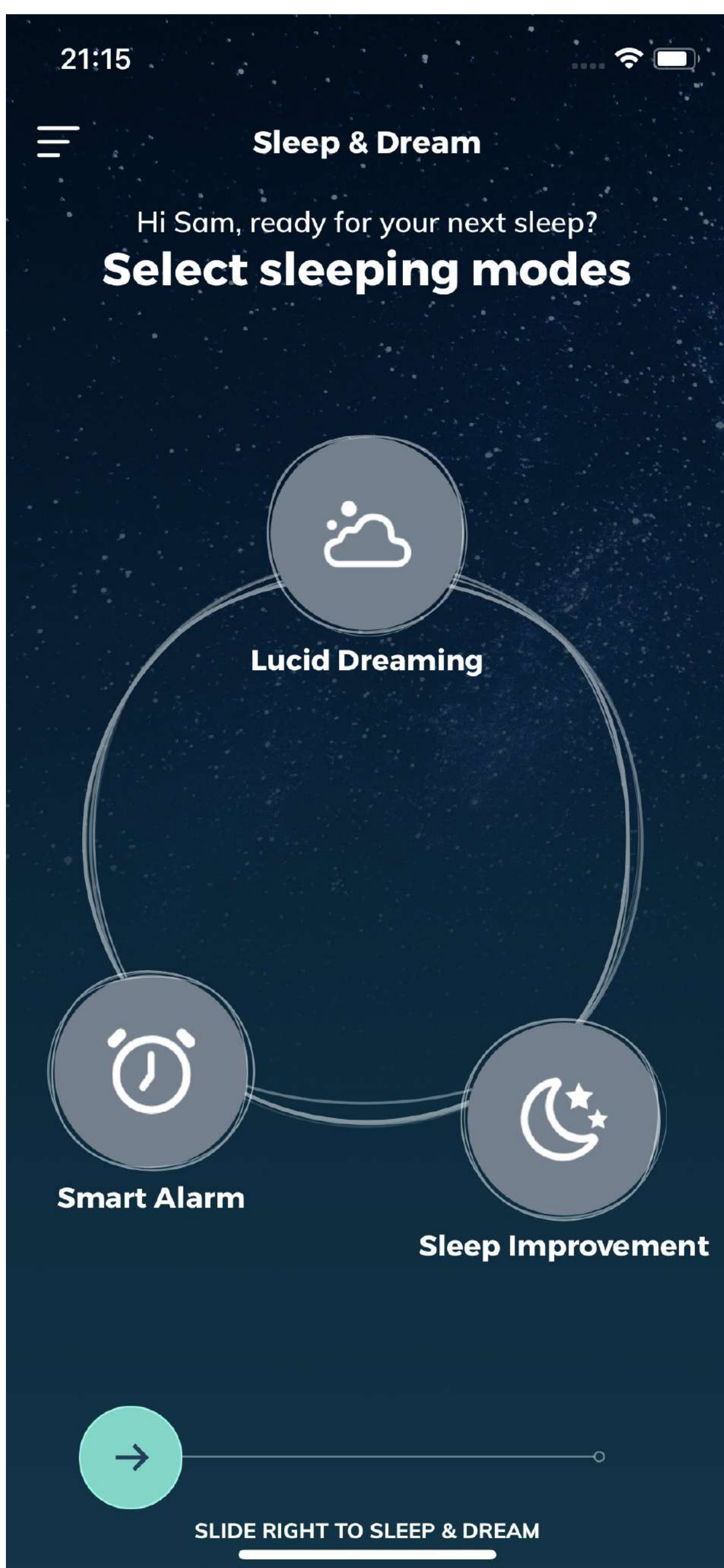



2. Go to the **Menu-> Settings** and choose your preferred audio-visual options and other settings for the desired application.

**Note:** "Settings" can be accessed only when the iBand+ headband is connected to the app.

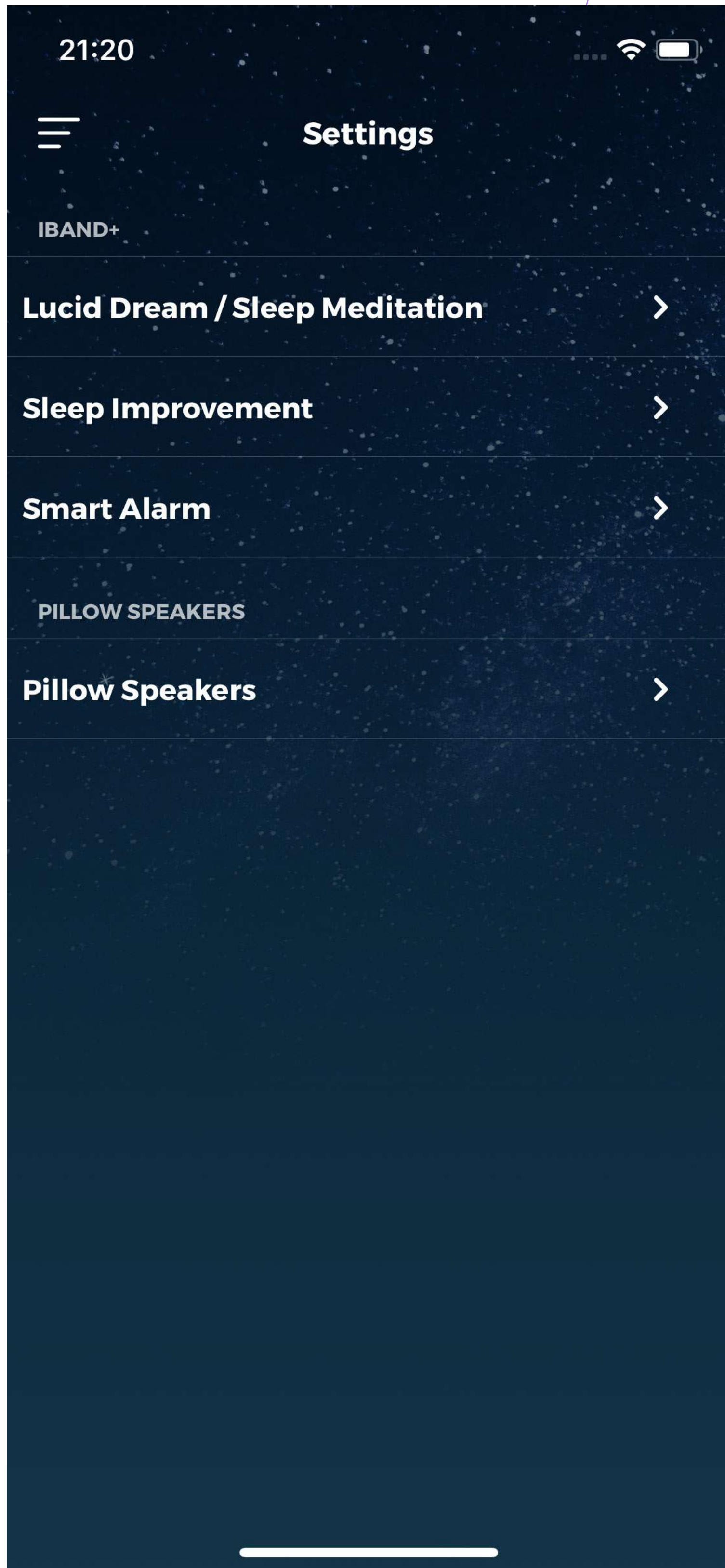



3. For Sleep Meditation, choose the option from the menu. Select your desired duration and then **SLIDE RIGHT TO START SLEEP MEDITATION**. We recommend selecting the **Autosleep** option in the beginning.

During sleep meditation, you can track your brainwaves in real-time right on the app. You can also **PAUSE** or **SLIDE LEFT TO STOP SLEEP MEDITATION**.

To learn more about this feature and make the best out of it, we advise you to watch the [Explainer videos](#) and also read the **Lucid Dreaming & Sleep Meditation** section in this user manual.

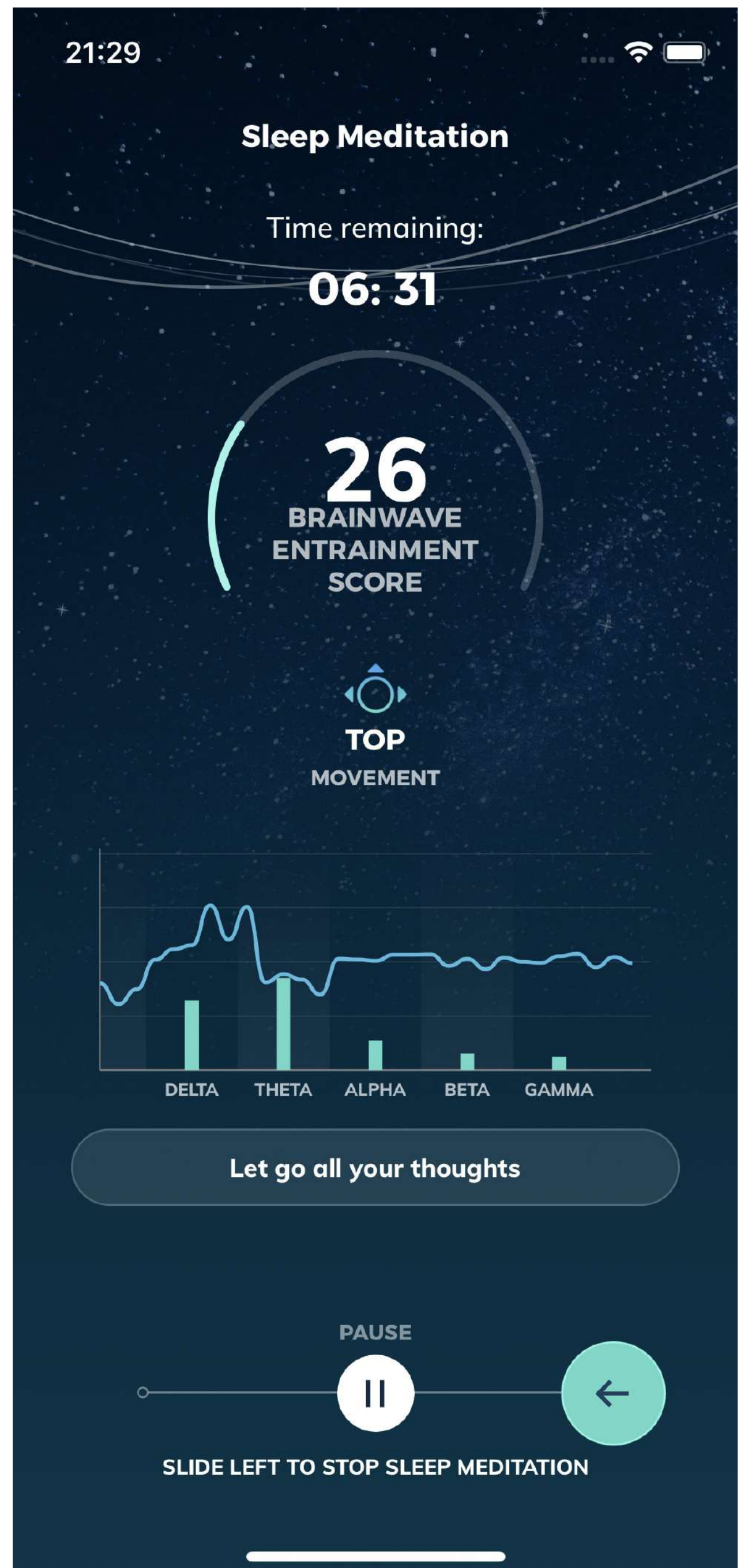
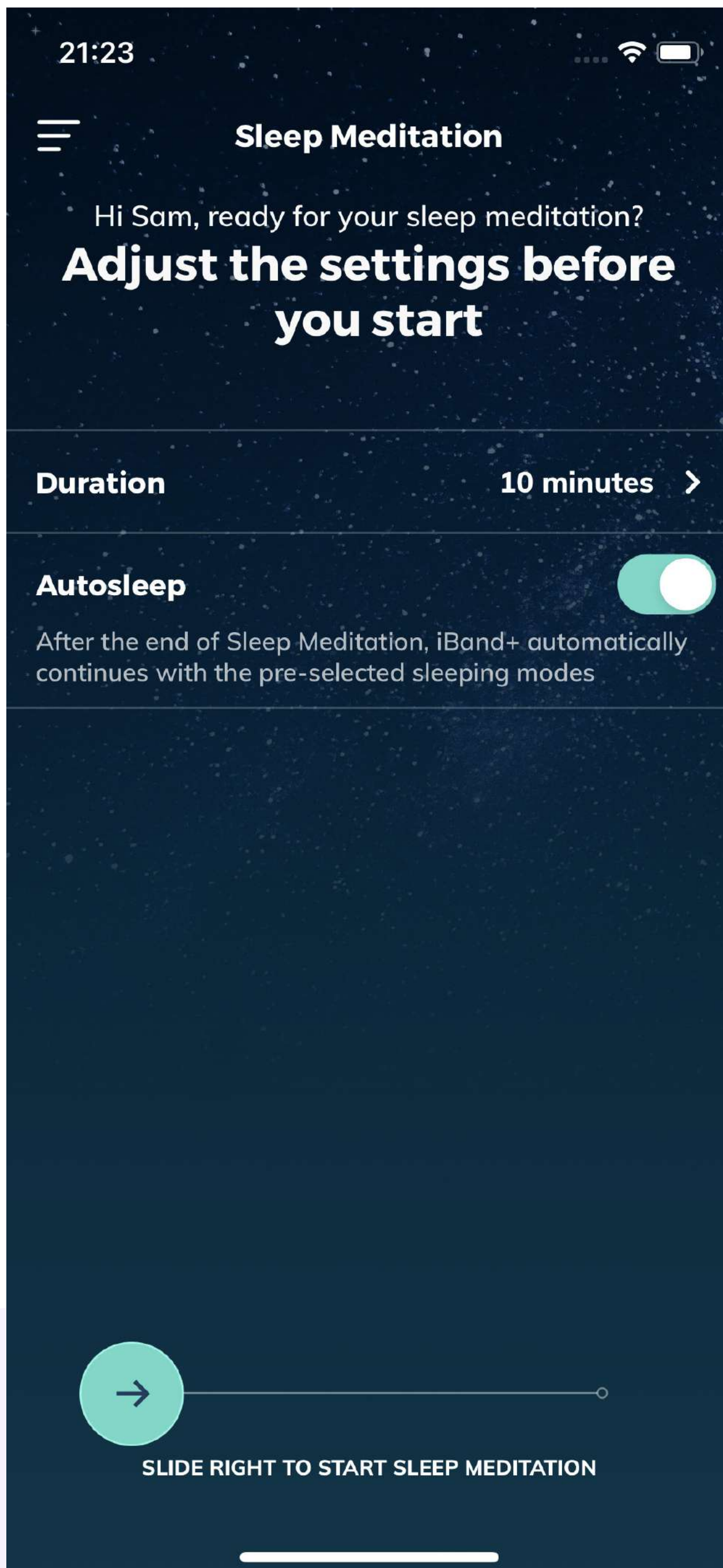

# TROUBLESHOOTING

## ● IBAND+ WON'T CONNECT WITH MY PHONE

Follow the steps below

1. Ensure that the iBand+ is fully charged.
2. Turn off your iBand+. Wait for 5 sec and turn it on again.  
Please make sure to read this guide in detail and follow all the steps mentioned in “Getting Started” in the correct order. If this doesn't work, then go to step 3.
3. Open the iBand+ app. Go to the menu and tap “Forget Device”. Then connect again via the app by following the instructions on your mobile screen.

### CONNECTING TO A NEW PHONE:

Before connecting your iBand+ to a new phone, remember to first “Forget Device” on your old phone (if applicable).

## ● DATA SYNCHRONIZATION NOT WORKING

1. iBand+ battery is fully drained.
2. If the Bluetooth connection could not be established:  
Turn off your iBand+. Wait for 5 sec and turn it on again.  
Quit the app and re-launch it.
3. **(For Android only)** Ensure that Battery Optimization for iBand+ app is turned off on your phone.



# SPECIFICATIONS

## PHYSICAL CHARACTERISTICS

PRODUCT	DIMENSIONS (L x W x T)	WEIGHT
iBand+ Headband	600 x 50 x 20 mm	45gm / 1.5oz
iBand+ Pillow Speakers	340 x 60 x 12 mm Wire 500mm	55gm / 2.0oz

## TECHNICAL SPECIFICATIONS

Smart Sensing	Gold plated dry EEG electrodes, 3D accelerometer for motion sensing
Audio-Visual Triggers	2 Multi-colored RGB LEDs, 2 High fidelity stereo pillow speakers
Battery	Built-in rechargeable LiPo battery 1.48Wh, 3 nights of sleep on full charge
Connectivity	Bluetooth 5.0 Low Energy, Bluetooth Classic, Micro USB

## MATERIALS

iBand+ Headband	Soft elastane fabric with anti-slip silicone grip
iBand+ Pillow Speakers	Soft velvet

## APP REQUIREMENTS

iOS	12 and above
Android	9 and above

## Compliance



## ATTENTION

**Risk of Strangulation:** DO NOT use the iBand+ headband and the iBand+ pillow speakers with the USB cable or any other cable plugged in. To avoid the risk of strangulation, iBand+ should always be worn without any cables attached.

**iBand+ is not a medical device.** For any medical or health-related professional advice, you should consult a doctor or a professional healthcare provider. If you have any physical, medical or neurological condition, please consult your doctor before using iBand+.

The iBand+ headband and the iBand+ pillow speakers are designed to be used by the users over the age of 18.

iBand+ sleep tracking data may be affected due to the electromagnetic interference (EMI) from the peripheral electronic devices like old adapters/chargers, fluorescent lamps, electric blankets etc. when they are ON.

 Do not use the device if you have any sores or skin irritation around the area where the electrodes make contact with skin. If you get any skin irritation after using the device, then stop immediately and consult a doctor before continuing.

*Please read the full [Safety Information](#) guide provided separately.*





[www.ibandplus.com](http://www.ibandplus.com)